



Bluetooth® Enabled  
Smart™ Sensors

NEW

# DST810 Smart™ Multisensor with Gen2 Paddlewheel



## Depth, Speed-Through-Water, Water Temperature, Boat Attitude

The new DST810 Smart Multisensor, featuring the new Gen2 paddlewheel and AIRMAR's CAST™ app, delivers a powerful combination of best-in-class speed performance and a simple, reliable way to calibrate accurate speed using your wireless device. The Gen2 paddlewheel delivers industry-leading start-up speed-through-water data below 0.3 knots and is linear at 0.6 knots, maintaining accurate performance up to 45 knots.

The DST810 and CAST app provide a simple, consistent way to calibrate speed-through-water. The free CAST app delivers calibration options that, until now, were only available through expensive PC-based software. In addition to water temperature, depth and newly upgraded 5.7 Hz (5X per second) speed-through-water output with improved speed resolution, the DST810 features an integrated attitude sensor for heel and trim data. This information, combined with Airmar's powerful and simple CAST app, makes heel-compensated speed calibration across multiple heel angles and speed ranges both fast and intuitive, and is independent of the onboard instruments.

### Features:

- **NEW!** DST810 now features the Gen2 paddlewheel for industry-leading speed performance from 0.3 knots to 45 knots.
- **Smoother Speed** – 5.7 Hz speed output (5X per second) for visibly smoother speed-through-water reporting and faster data for better decision making when every second counts.
- **Integrated Attitude Sensor** – for heel and trim and used in advanced speed calibration.
- Wireless connectivity to Airmar's CAST app has new user-friendly benefits:
  - Calibrate the DST810 in a simple, intuitive way from your mobile device.
  - Conduct basic and advanced heel-compensated speed calibrations for improved speed-through-water outputs across the speed range.
  - Advanced speed calibration allows for manual speed entries for multiple heel angles and up to 10 speeds, formerly only possible through expensive PC software.



Now Featuring!

**Gen2**  
PADDLEWHEEL



**AIRMAR®...IT'S WHAT'S UNDER YOUR BOAT.**

**AIRMAR®**  
TECHNOLOGY CORPORATION

# Introducing the Paddlewheel That Sets the Standard for Performance



Airmar's new, next-generation paddlewheel design delivers industry-leading performance for start-up responsiveness and linearity throughout the speed range. Gen2 paddlewheel maintains the top speed performance Airmar is known for and adds start-up speed performance that beats all other available paddlewheels. The Gen2 paddlewheel is the most sensitive and accurate paddlewheel available for sailing and power boats.

## Key benefits of the new Gen2 paddlewheel include:

- Ultra-responsive speed begins as low as 0.3 knots and becomes linear at 0.6 knots.
- Speed-through-water readings stay accurate and smooth through 45 knots.

## Speed Comparison Versus Competition

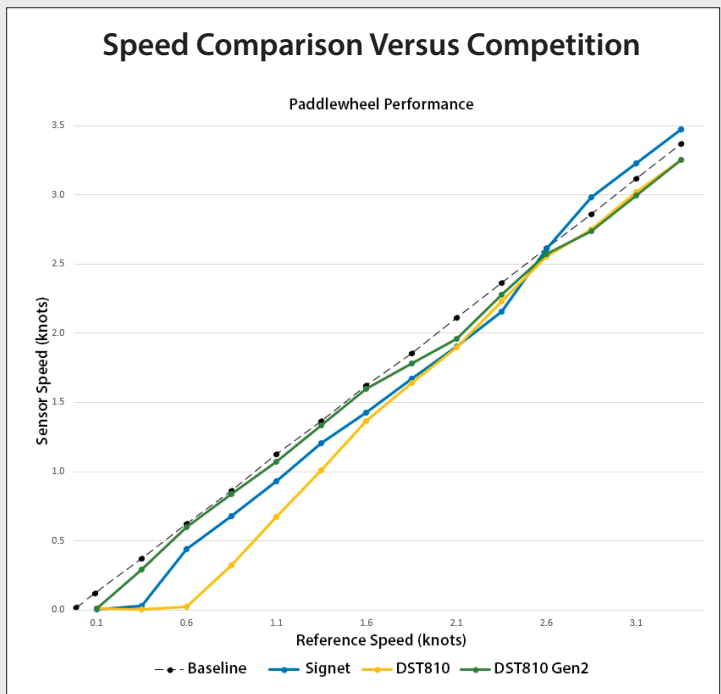

## SPECIFICATIONS

### Weight:

- 0.9 kg (2.0 lb)—Plastic
- 1.6 kg (3.5 lb)—Bronze
- 1.9 kg (4.2 lb)—Stainless Steel

**Acoustic Window:** Urethane

**Hull Deadrise:** Up to 22°

**Data Update Rate:** Depth: 1X/second  
Speed: 5X/second  
Heel/Trim: 10X/second

**Attitude Accuracy:** +/- 1° nominal after sensor calibration

**Depth Frequency:** 235 kHz

**Minimum Depth Range:** 0.5 m (1.6')

**Maximum Depth Range:** Up to 100 m (330')—NMEA 2000®

**Speed Range:** 0.3 knots to 45 knots

**Pressure Rating:** 3 m (10')

**Supply Voltage:** 9 VDC to 16 VDC— per NMEA 2000®

**Supply Current:** <200 mA— per NMEA 2000®

**Wireless Protocol:** Bluetooth Low Energy (BLE)

**Wireless Range:** Up to 30 feet depending on mount location

**Standard Cable Length:** 6 m (20') DeviceNet—NMEA 2000®

**Temperature Sensor Accuracy:** ±0.5°C (±1.8°F)

**Temperature Sensor Range:** -10°C to 40°C (14°F to 104°F)

**NMEA 2000® Load Equivalency Number (LEN):** 3

**CE Regulation:** Complies to IERC60945

## CAST App With DST810



Use the Airmar CAST™ app to calibrate speed at multiple heel angles and numerous speeds for optimal performance.

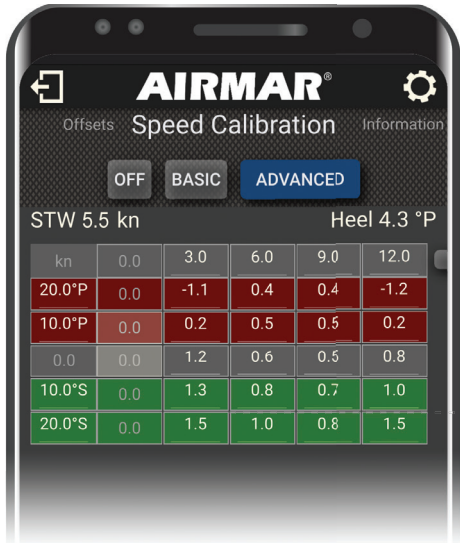

Wirelessly connects

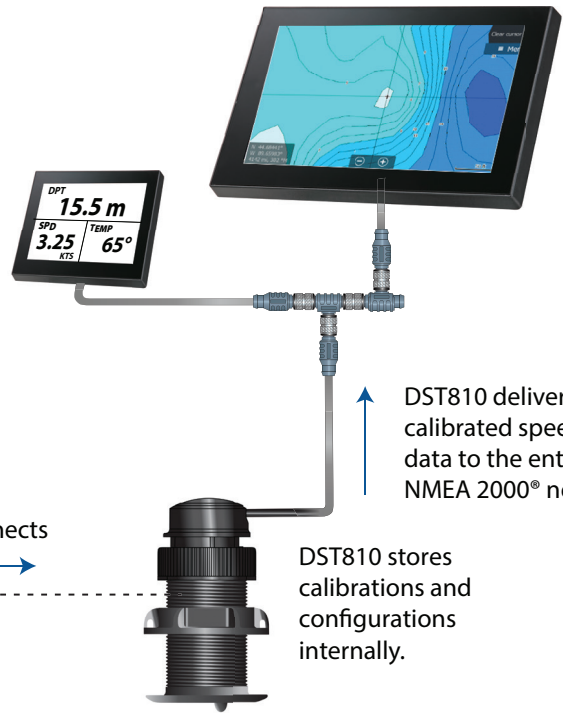

DST810 delivers calibrated speed data to the entire NMEA 2000® network.

DST810 stores calibrations and configurations internally.

Calibrate speed at 5 heel angles and up to 10 speeds



Configure outputs

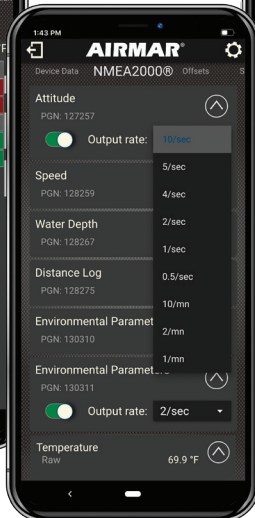

Display data / gauges



Calibrate basic or heel compensated speeds with DST810 connectivity



Configure offsets and calibrate attitude



CAST connects to DST810, DX900+, and SmartBoat Modules



## DATA OUTPUT PROTOCOL

### NMEA 2000® Supported PGNs

|             |  |
|-------------|--|
| 059904..... | ISO Request                                  |
| 060928..... | ISO Address Claim                            |
| 065240..... | Commanded Address                            |
| 59392.....  | ISO Acknowledgement                          |
| 126208..... | Acknowledge Group Function                   |
| 126464..... | Transmit PGN List Group Function             |
| 126464..... | Received PGN List Group Function             |
| 126993..... | Heartbeat                                    |
| 126996..... | Product Information                          |
| 126998..... | Configuration Information                    |
| 127257..... | Attitude                                     |
| 128259..... | Speed (Speed Water Reference)                |
| 128267..... | Water Depth (With Transducer Offset)         |
| 128275..... | Distance Log                                 |
| 130310..... | Environmental Parameters (Water Temperature) |
| 130311..... | Environmental Parameters (Water Temperature) |
| 130312..... | Environmental Parameters (Water Temperature) |
| 130316..... | Temperature, Extended Range                  |

### Proprietary PGNs

|                |                                |
|----------------|--------------------------------|
| 126720-33..... | Attitude Offsets               |
| 126720-67..... | Attitude Filter                |
| 126720-68..... | Basic speed heel correction    |
| 126720-69..... | Advanced speed heel correction |
| 126720-71..... | Disable speed heel correction  |

## DIMENSIONS

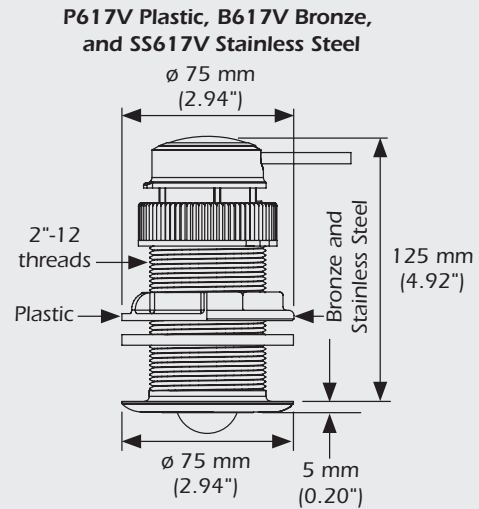

Airmar's innovative housing design incorporates a self-closing valve to minimize water flow into boat when the insert is removed.



[www.airmar.com](http://www.airmar.com)

©2023 Airmar Technology Corporation

DST810\_r1 02/11/26

As Airmar constantly improves its products, all specifications are subject to change without notice. All Airmar products are designed to provide high levels of accuracy and reliability, however they should only be used as aids to navigation and not as a replacement for traditional navigation aids and techniques. Smart™ is a trademark of Airmar Technology Corporation. The Bluetooth® word mark and logos are registered trademarks owned by Bluetooth SIG, Inc. and any use of such marks by Airmar Technology Corporation is under license. Other company or product names mentioned in this document may be trademarks or registered trademarks of their respective companies, which are not affiliated with Airmar.

