



APPENDIX

ALPHA ALTERNATOR

DIMENSIONS, INSTALLATION DRAWINGS AND CHARACTERISTICS



TABLE OF CONTENTS

1	DIMENSIONS	3
1.1	Dimensions Alpha alternator model 12/90	3
1.2	Dimensions Alpha alternator models 12/130, 24/75 and 24/110	4
1.3	Dimensions Alpha alternator model 24/150	5
1.4	Dimensions Alpha Pro III regulator	6
2	INSTALLATION DRAWINGS AND INSTRUCTIONS	7
2.1	Alpha Alternator model 12/90	7
2.2	Alpha Alternator models 12/130, 24/75 and 24/110	8
2.3	Alpha Alternator model 24/150	9
2.4	Standard Bosch alternator	10
2.5	Instruction for modification of standard Bosch alternators	11
2.6	Installation examples for Alpha alternator model 12/90	12
2.7	Installation examples for Alpha alternator models 12/130, 24/75 and 24/110	14
3	CHARACTERISTICS	15
3.1	Charge current versus RPM	15

1 DIMENSIONS

1.1 DIMENSIONS ALPHA ALTERNATOR MODEL 12/90

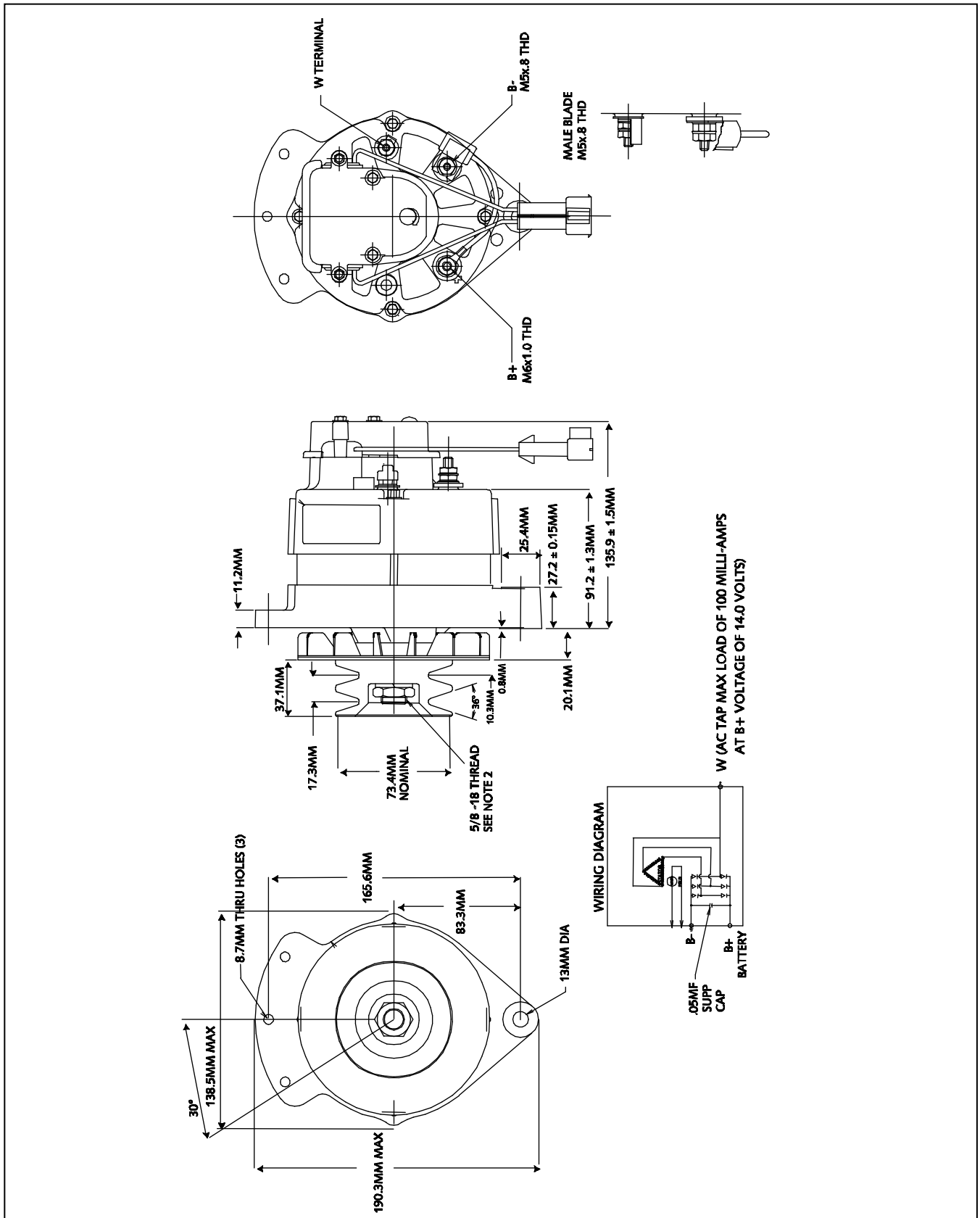

Figure A-1: Dimensions Alpha alternator model 12/90 (enclosure A)

1.2 DIMENSIONS ALPHA ALTERNATOR MODELS 12/130, 24/75 AND 24/110

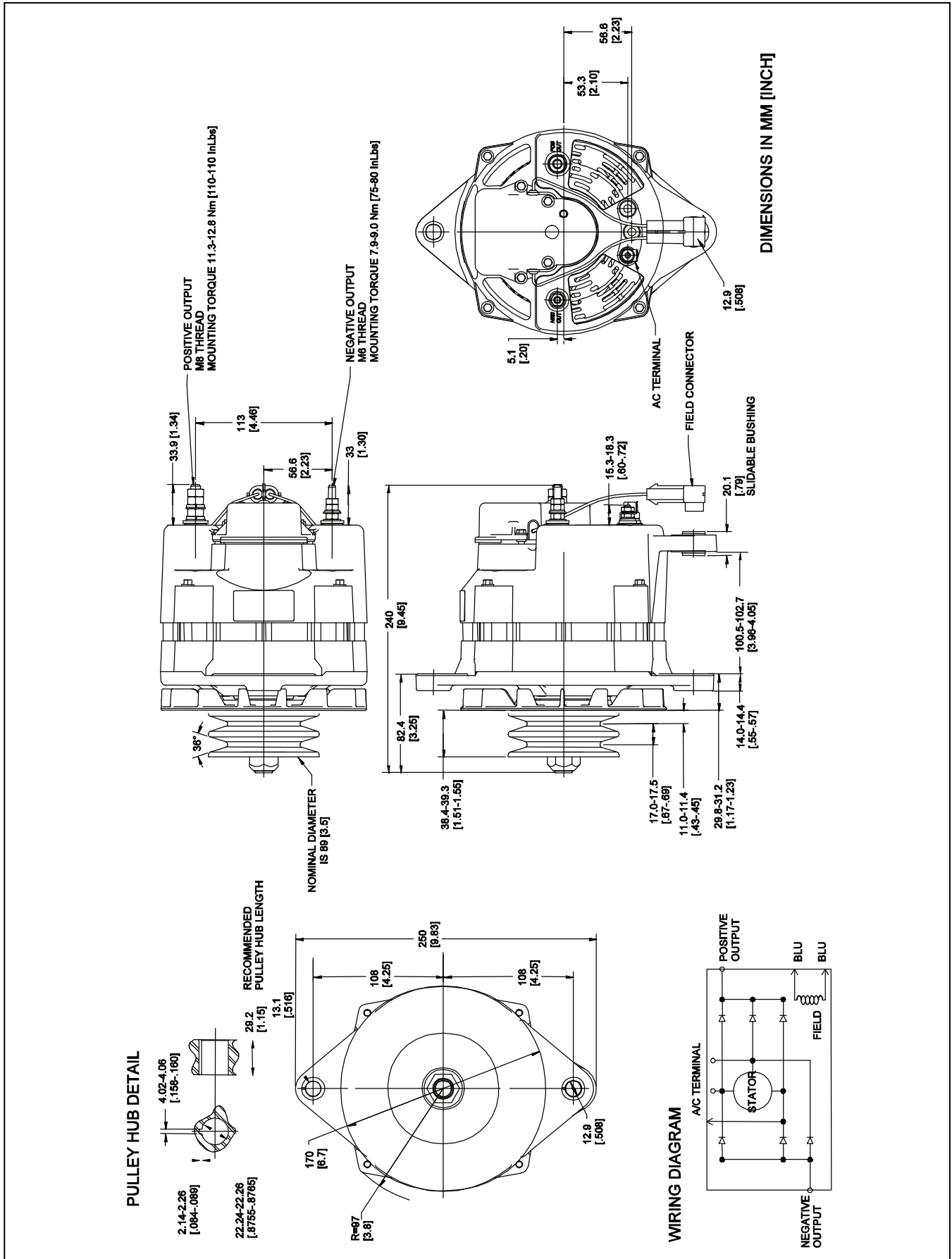

Figure A-2: Dimensions Alpha alternator models 12/130, 24/75, 24/110 and 24/150 (enclosure B)

1.3 DIMENSIONS ALPHA ALTERNATOR MODEL 24/150

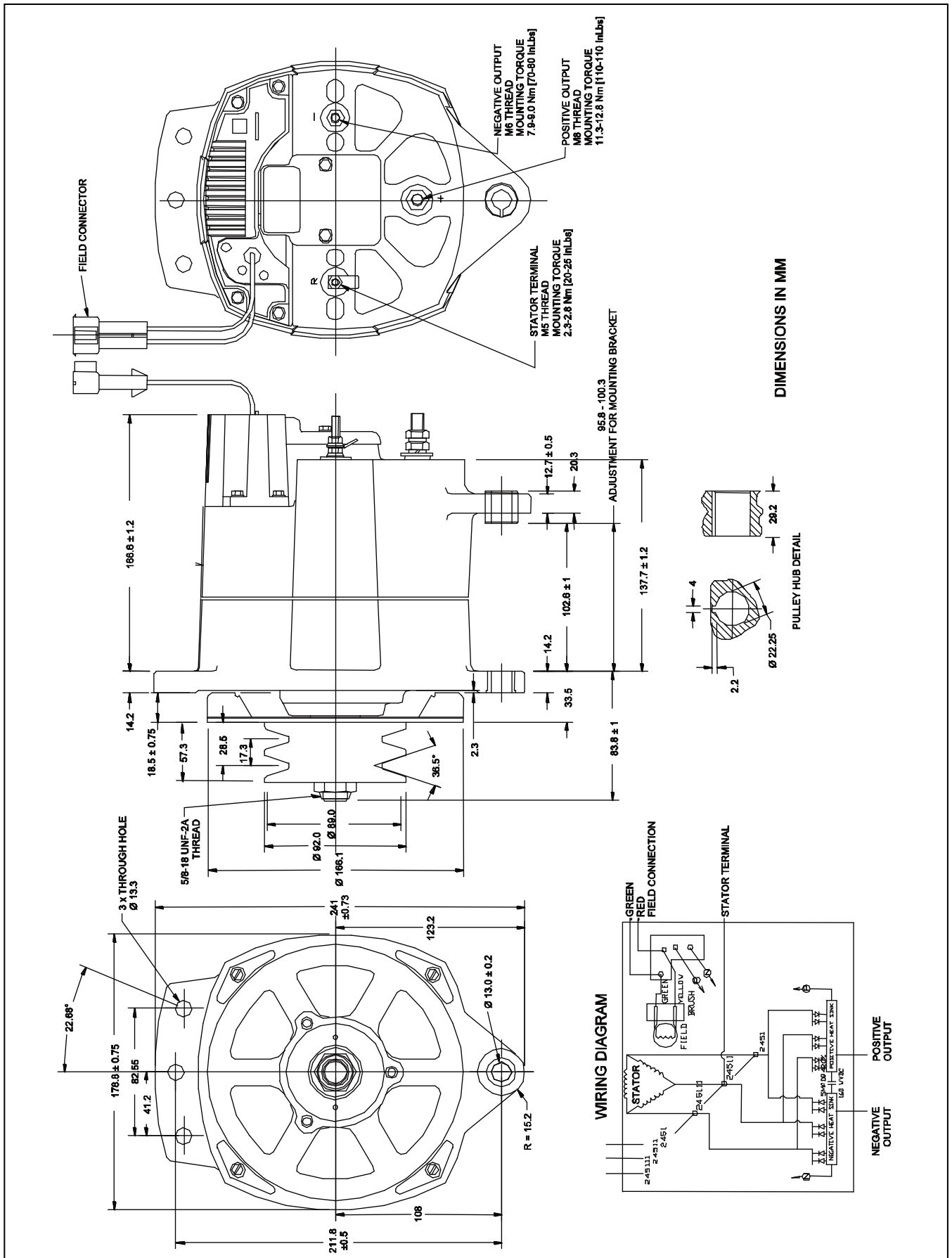

Figure A-3: Dimensions Alpha alternator model 24/150 (enclosure C)

1.4 DIMENSIONS ALPHA PRO III REGULATOR

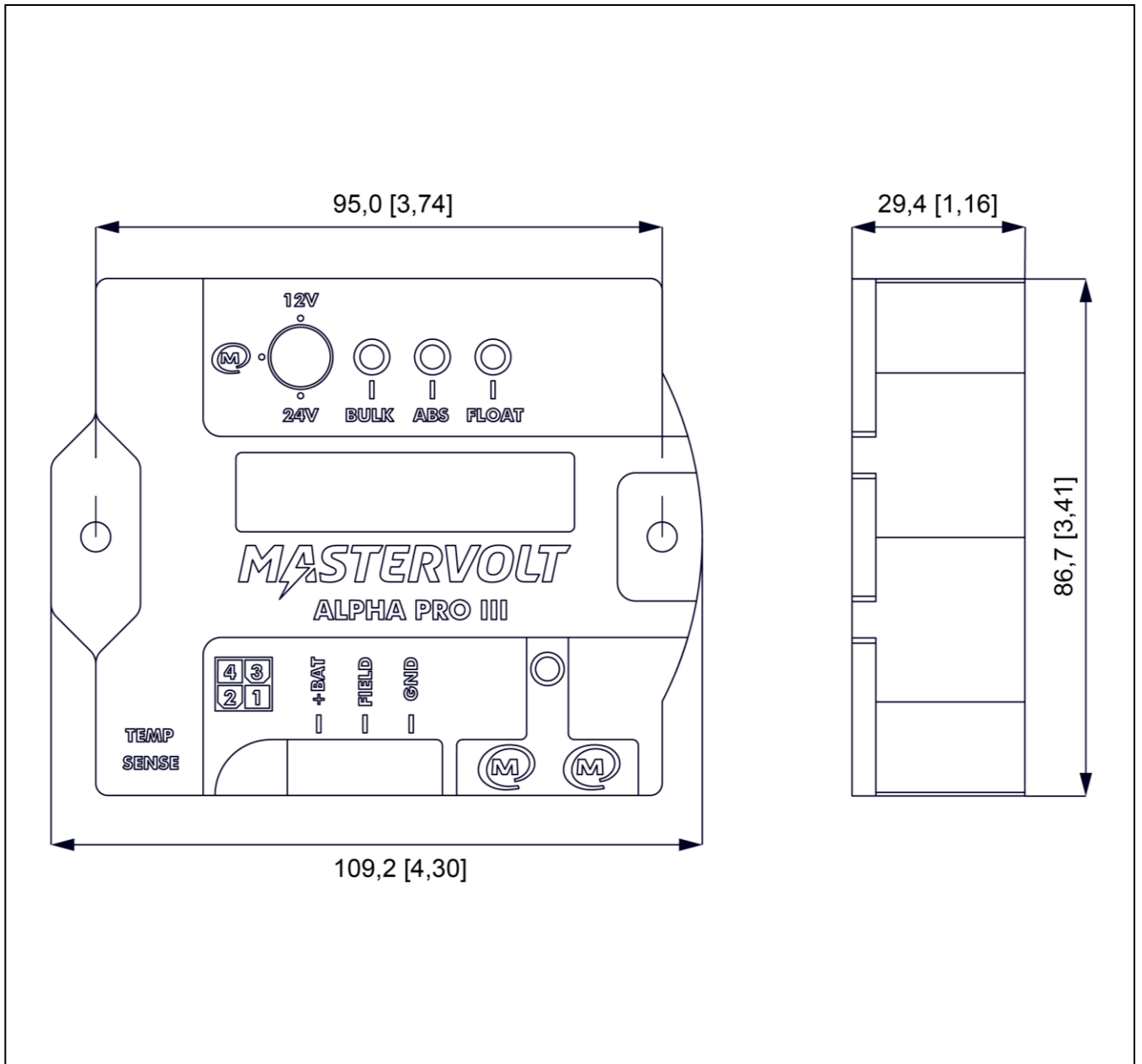

Figure A-5: Dimensions of the Alpha Pro III regulator (all models)

2 INSTALLATION DRAWINGS AND INSTRUCTIONS

2.1 ALPHA ALTERNATOR MODEL 12/90

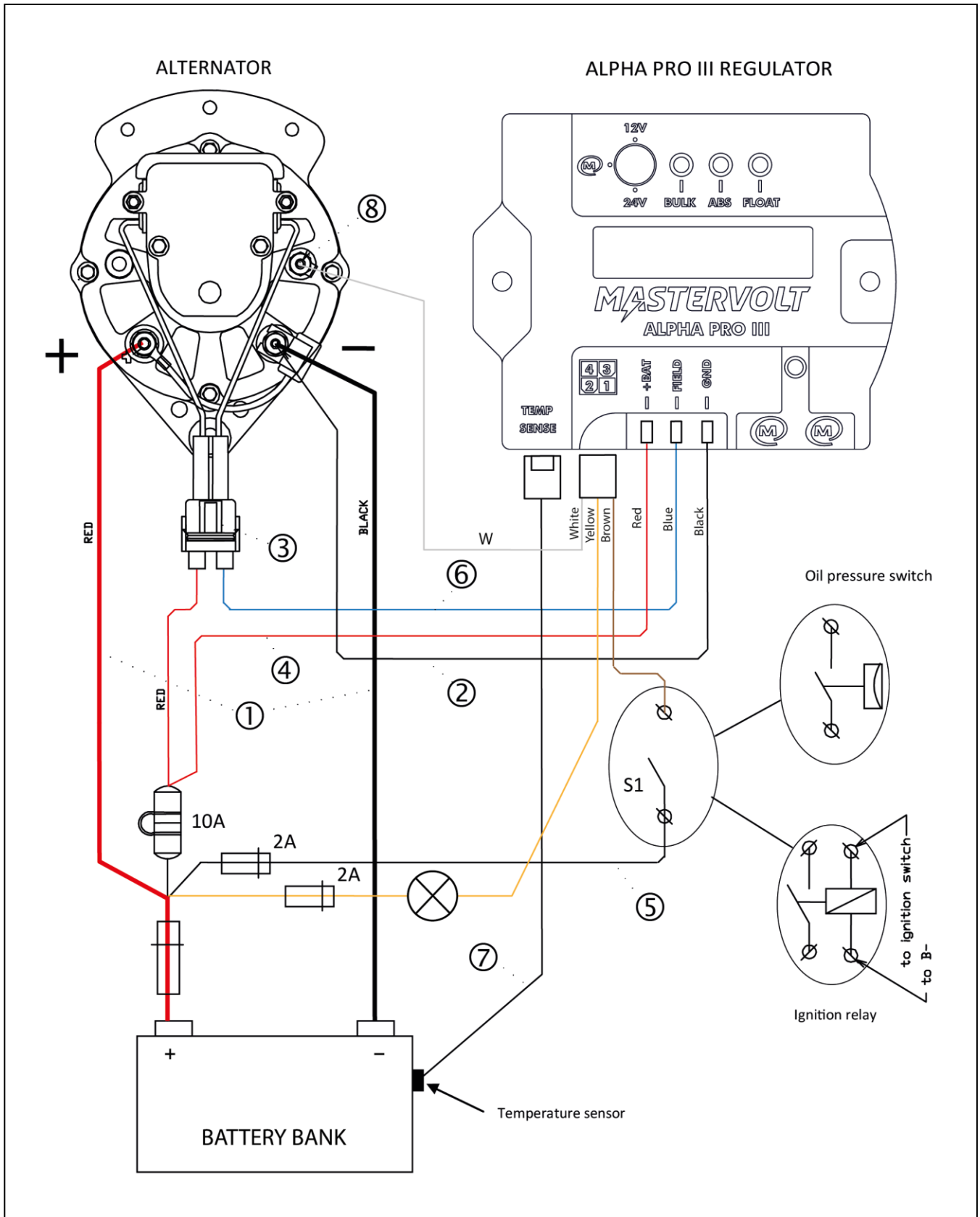

Figure A-6: Installation drawing Alpha alternator model 12/90

2.2 ALPHA ALTERNATOR MODELS 12/130, 24/75 AND 24/110

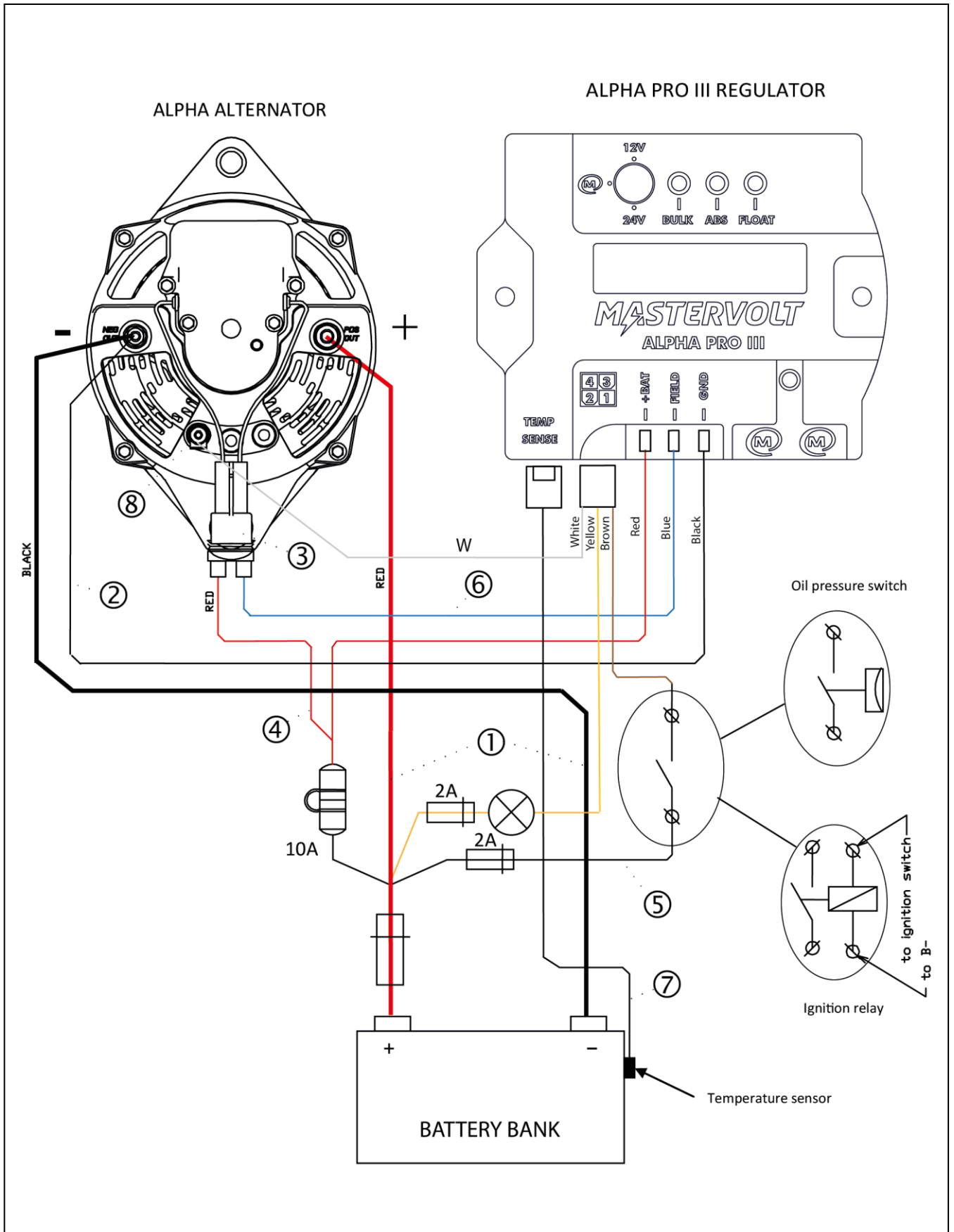

Figure A-7: Installation drawing Alpha alternator models 12/130, 24/75 and 24/110

2.3 ALPHA ALTERNATOR MODEL 24/150

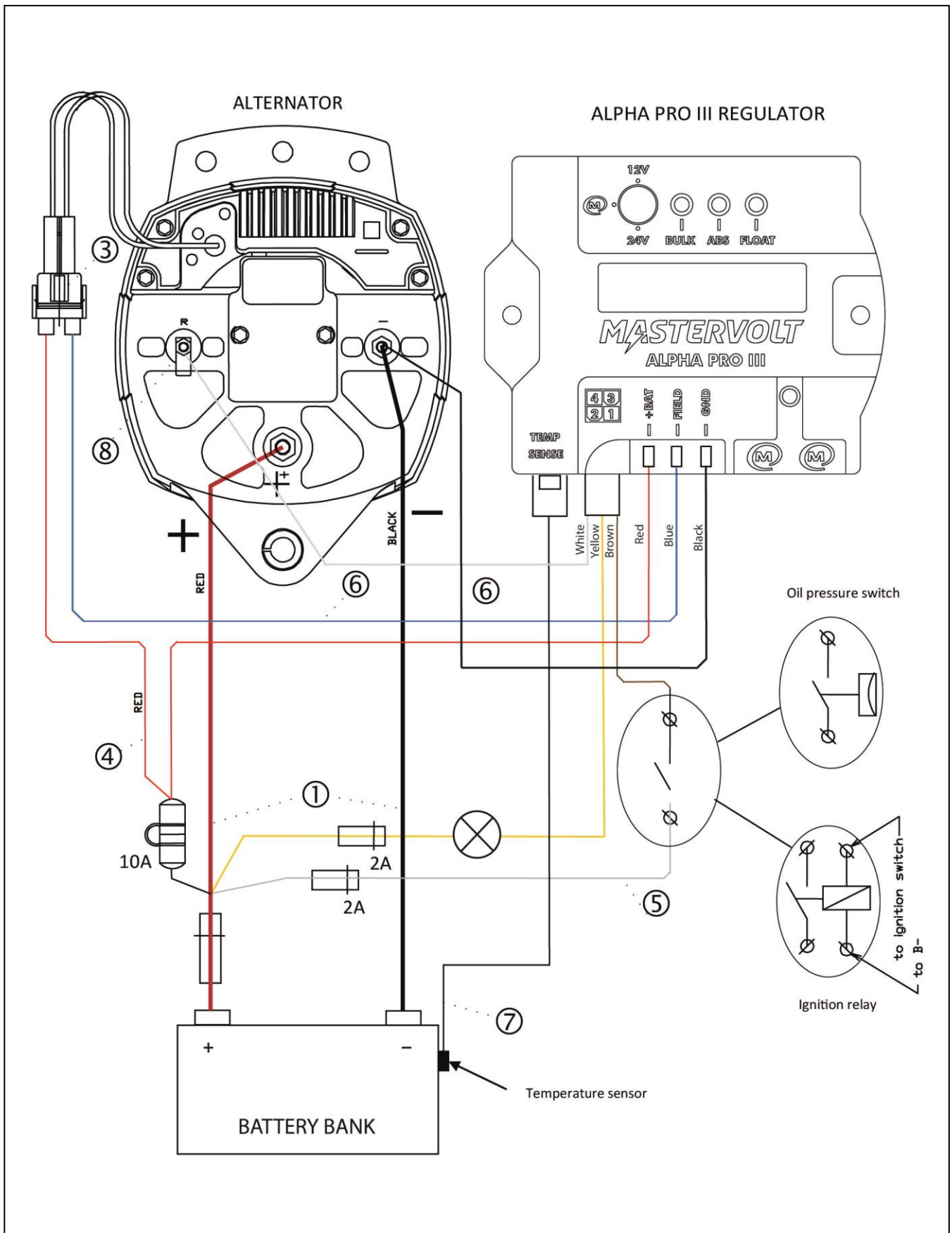

Figure A-8: Installation drawing Alpha alternator model 24/150

2.4 STANDARD BOSCH ALTERNATOR

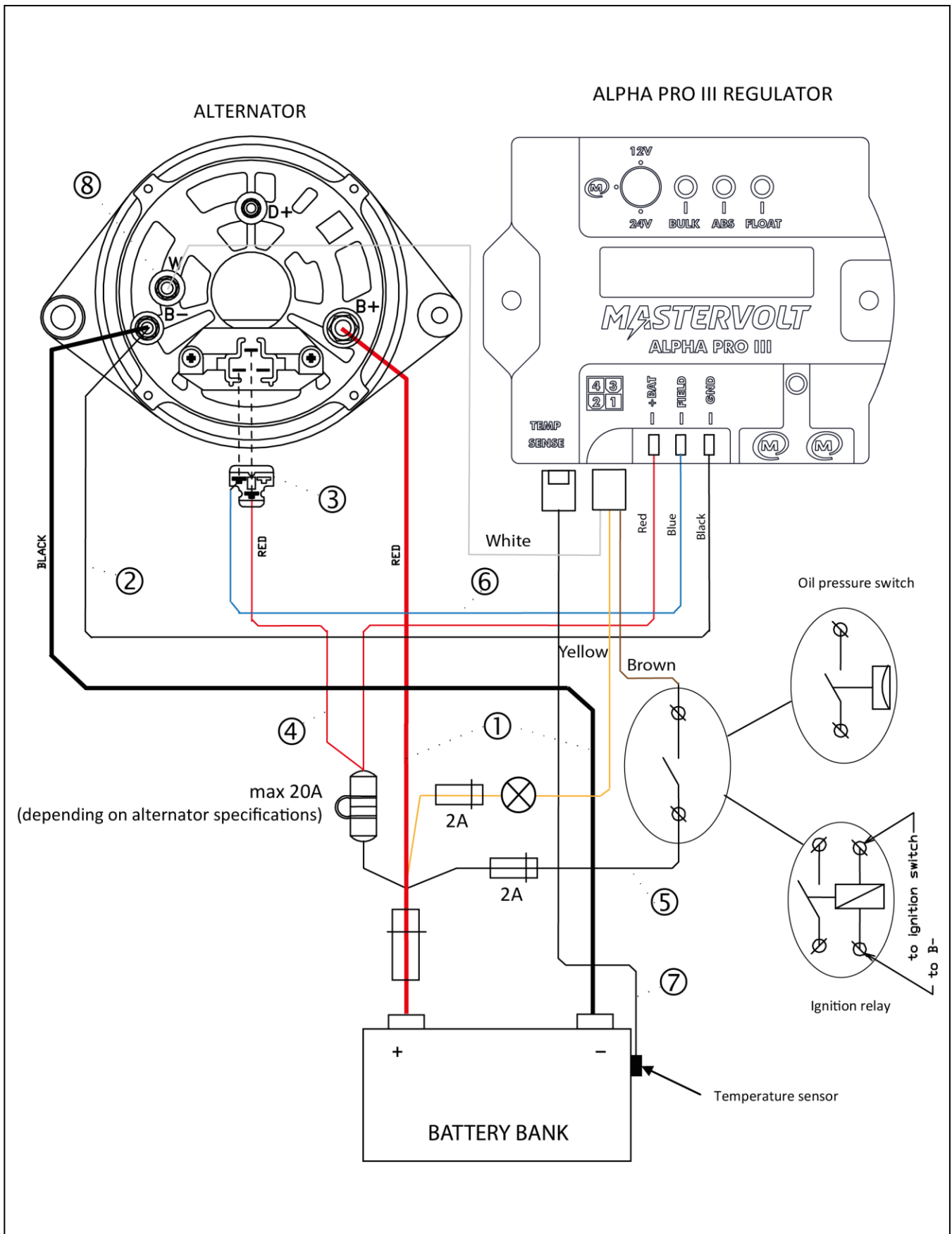

Figure A-9: Installation drawing standard Bosch alternator

2.5 INSTRUCTION FOR MODIFICATION OF STANDARD BOSCH ALTERNATORS

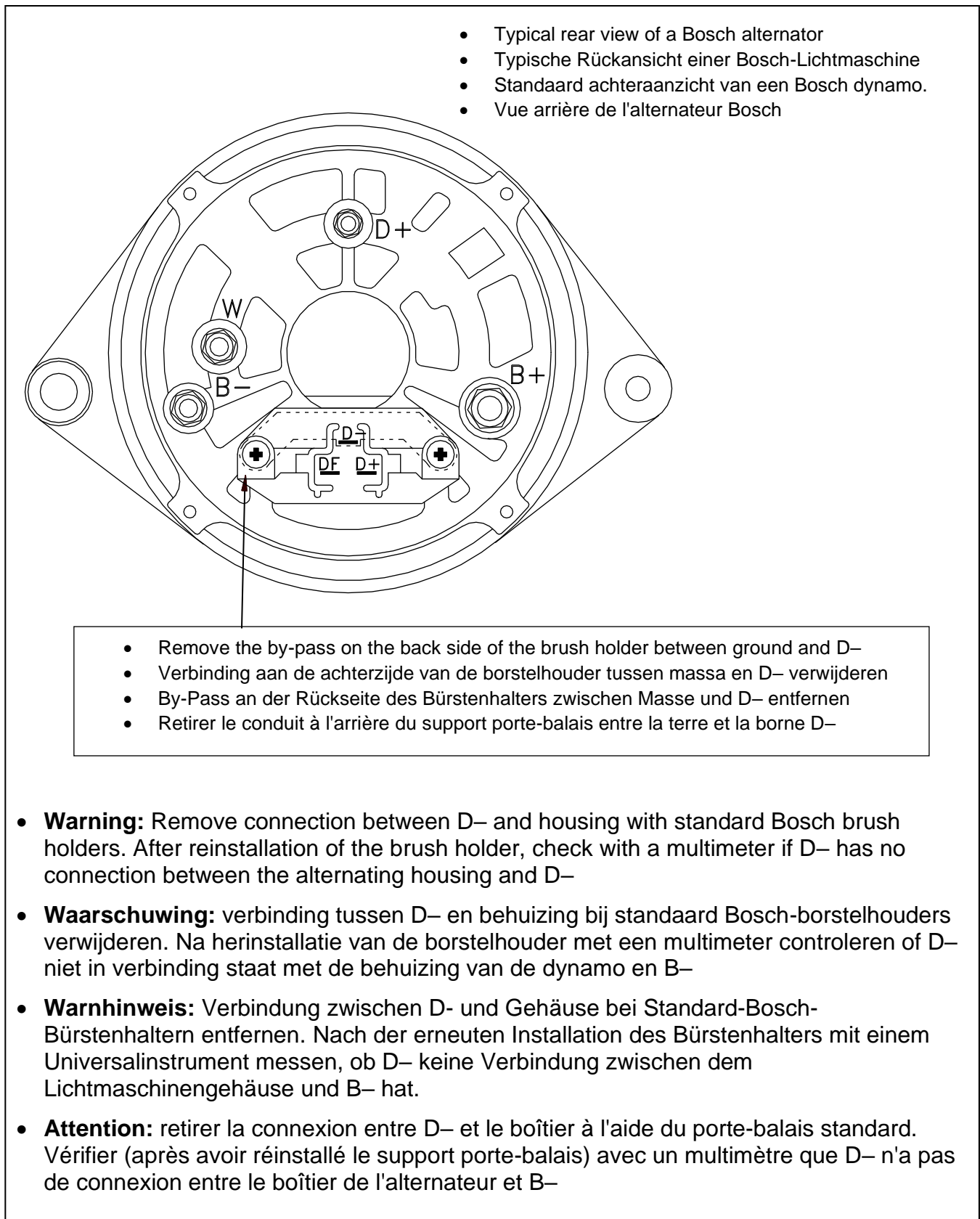

Figure A-10: Standard Bosch alternator (not applicable for Mastervolt alternators)

2.6 INSTALLATION EXAMPLES FOR ALPHA ALTERNATOR MODEL 12/90

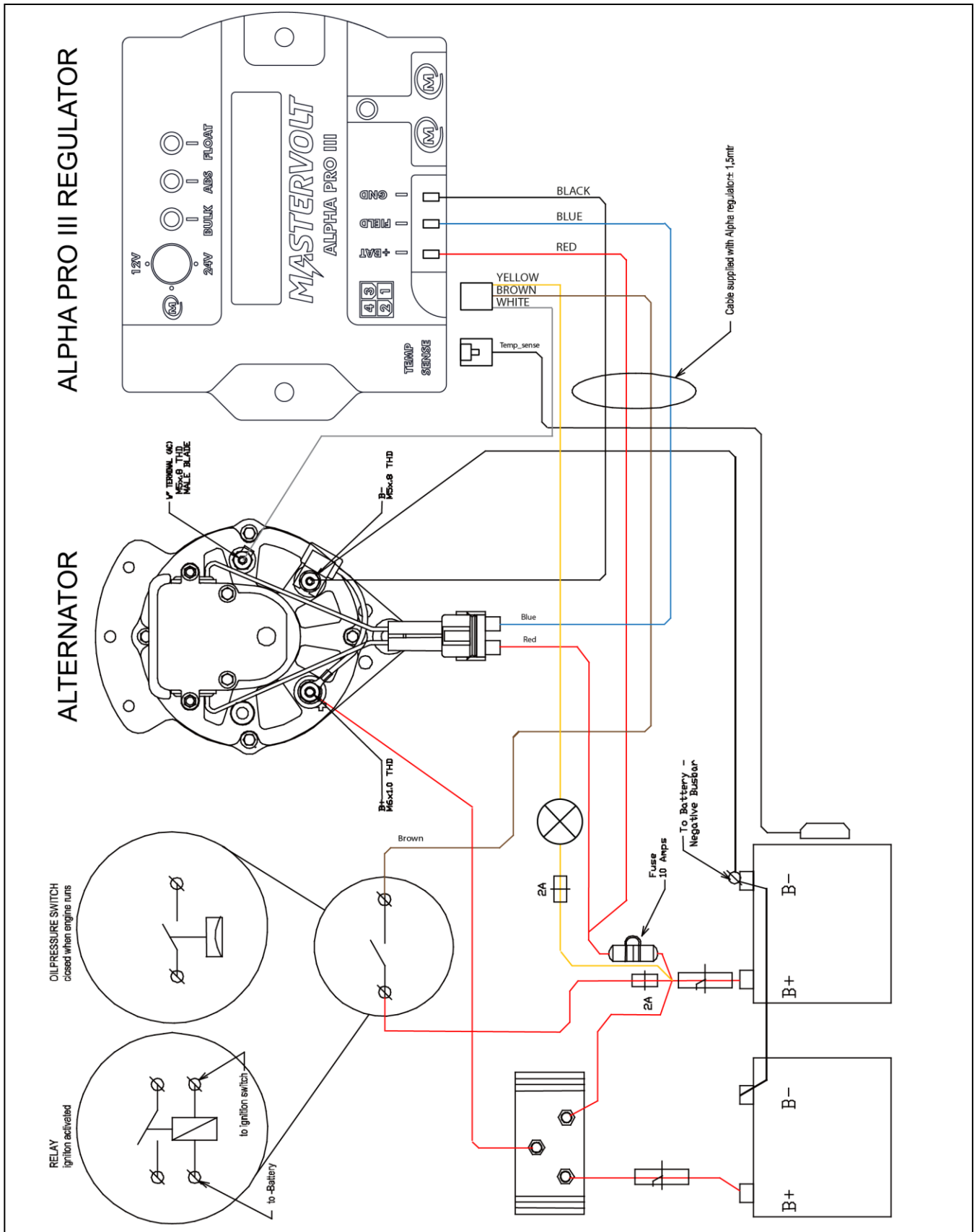

Figure A-11: This drawing shows the installation of the Alpha alternator 12/90 in combination with a battery isolator to charge two battery banks simultaneously

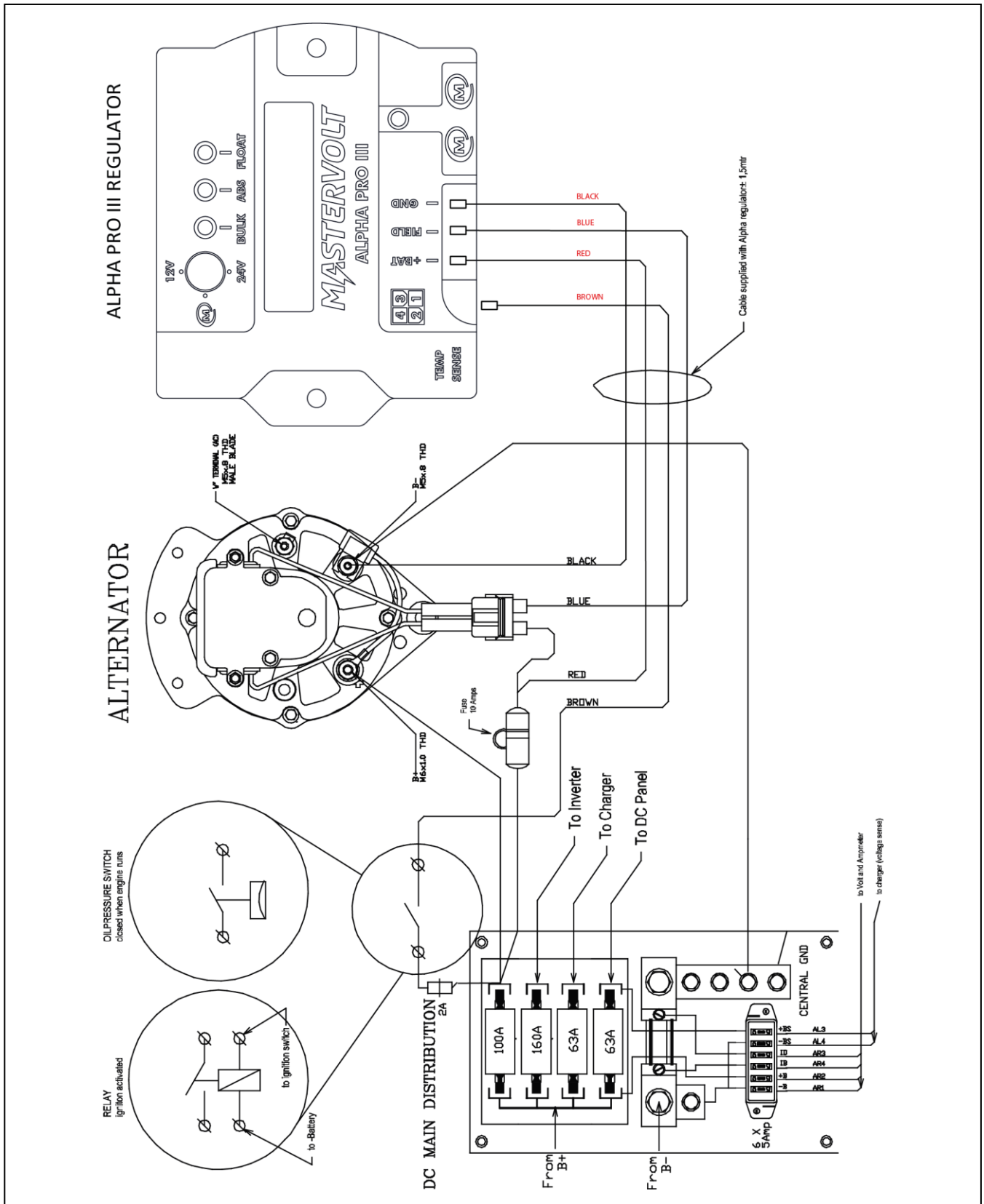

Figure A-12: Here the installation of the Alpha alternator 12/90 in combination with a Mastervolt DC distribution system is shown. The Mastervolt DC distribution systems are easy-to-install installation kits for central connection of the DC-sources (such as the alternator and the battery charger), the batteries and the DC loads (such as the inverter, the anchor winch or the bow thruster). These DC-distribution systems are standard pre-wired for connection of a battery monitor. See www.mastervolt.com for details.

2.7 INSTALLATION EXAMPLES FOR ALPHA ALTERNATOR MODELS 12/130, 24/75 AND 24/110

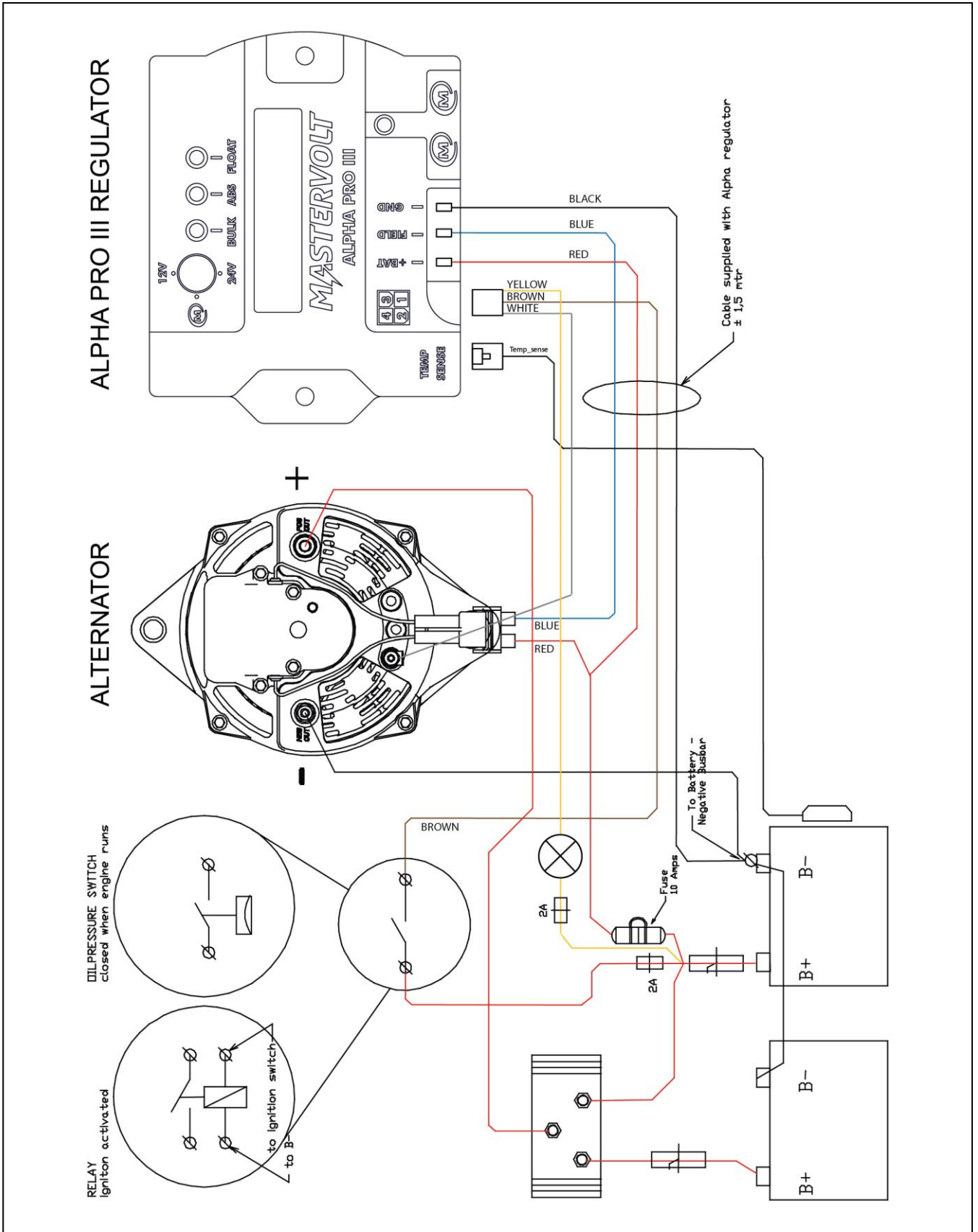
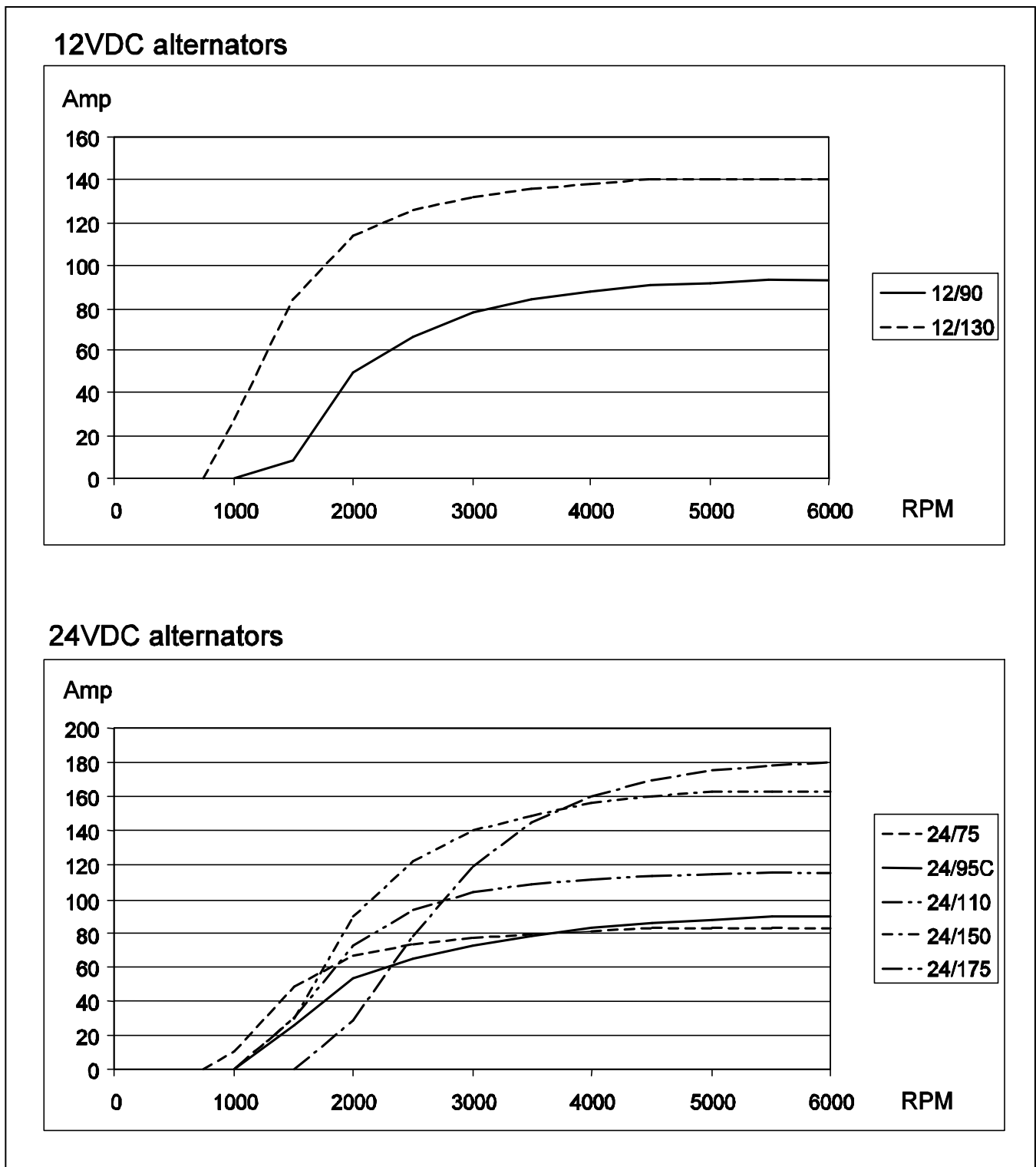

Figure A-13: This drawing shows the installation of the Alpha alternator models 12/130, 24/75 and 24/110 in combination with a battery isolator to charge two battery banks simultaneously.

3 CHARACTERISTICS

3.1 CHARGE CURRENT VERSUS RPM



Output power is measured in combination with Alpha Pro III regulator at nominal voltage (25°C)

Figure A-15: Characteristics for Mastervolt alternators: charge current versus RPM



Europe, Middle East & Africa

Customer Service

T: +31 (0) 20 34 22 100
E: info@mastervolt.com

Technical Support

T: +31 (0) 20 34 22 100
E: ts@mastervolt.com

Location & Shipping

Mastervolt
Snijdersbergweg 93
1105 AN Amsterdam
The Netherlands

Americas & Caribbean

Customer Service

T: +1 800 307 6702, Option 1
E: orderentry@marinco.com

Technical Support

T: +1 800 307 6702, Option 2
E: tsusa@mastervolt.com

Location & Shipping

Power Products, LLC
N85 W12545 Westbrook Crossing
Menomonee Falls, Wisconsin 53051
United States

Asia Pacific

Customer Service

T: +64 9 415 7261 Option 1
E: enquiries@bepmarine.com

Technical Support

T: +64 9 415 7261 Option 3
E: technical@bepmarine.com

Location & Shipping

BEP Marine
42 Apollo Drive
Rosedale, Auckland 0632
New Zealand